

# CLASSIC 260

(Short Shaft)

# SPECIFICATIONS

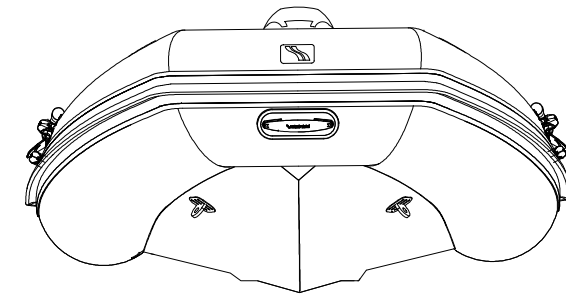
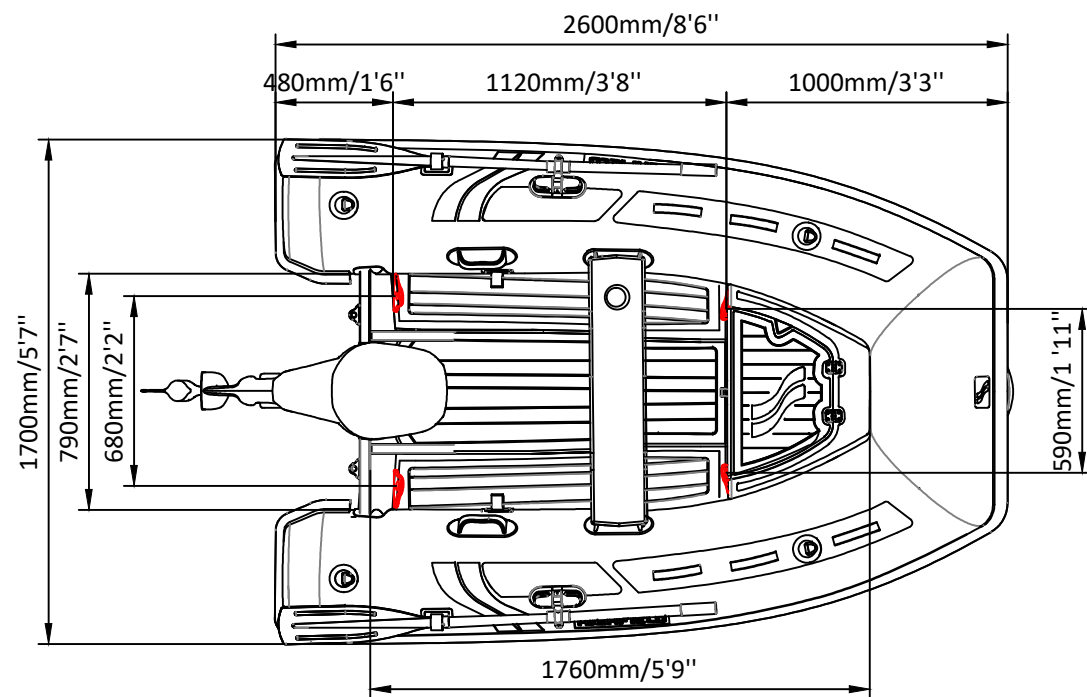
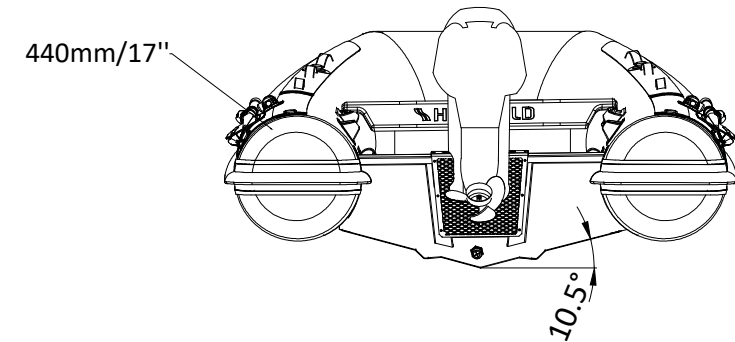
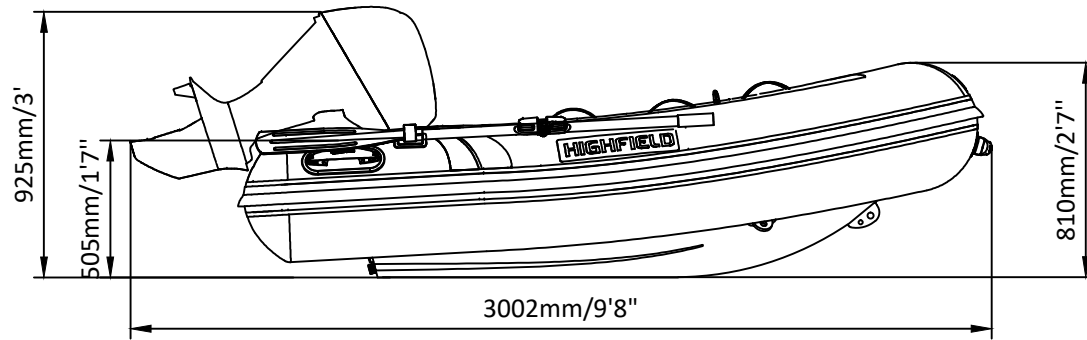

SPECIFICATIONS AND MAXIMUM CAPACITIES (Subject to change without notice. Tolerances: Dimensions ±2.5% Weight ±5%) Note: red means lifting eyes.

| MODEL | ISO 6185 PART | ISO 6185 | Crew            |                  | #   | Weight |     | Shaft | Outboard Engine |    | Molded seat |     | Oars |     | Fuel tank Capacity |     | Wet Weight (Approximate)<br>15HP (11.19KW) |     | AIR CHAMBERS | Pressure |     |   |     |     |   |      |      |
|-------|---------------|----------|-----------------|------------------|-----|--------|-----|-------|-----------------|----|-------------|-----|------|-----|--------------------|-----|--|-----|--------------|----------|-----|---|-----|-----|---|------|------|
|       |               |          | KG              | LB               |     | KG     | LB  |       | KG              | LB | KG          | LB  | KG   | LB  | L                  | GAL | KG   | LB  |              | PSI      | BAR |   |     |     |   |      |      |
|       |               |          | Max power<br>KW | Max weight<br>HP |     | KG     | LB  |       | KG              | LB | KG          | LB  | KG   | LB  | /                  | /   | /  | /   |              | KG       | LB  |   |     |     |   |      |      |
| CL260 | 2             | C        | 360             | 794              | 3+1 | 263    | 579 | S     | 11.19           | 15 | 60          | 132 | 54   | 119 | 3                  | 6.6 | 1.5  | 3.3 | /            | /        | /   | / | 118 | 262 | 3 | 3.63 | 0.25 |

Weight: boat only.